

TT 2113
BATH SUPPORT BRACKET
FOR STANDPIPES
INSTALLATION GUIDE

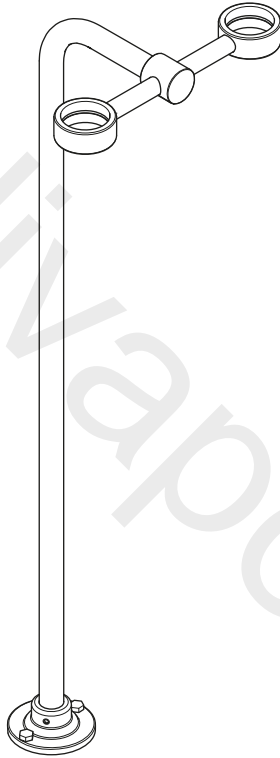

LEFROY BROOKS

IMPORTANT INFORMATION

Professional installation

We recommend that our products are fitted by a fully qualified professional plumber. They should be installed correctly and in accordance with all local water regulations. All products should be accessible for routine servicing.

Important

The standpipe support must be fitted at the same time as the standpipes **before** the bath filler or bath shower mixer is fitted.

DIMENSIONS

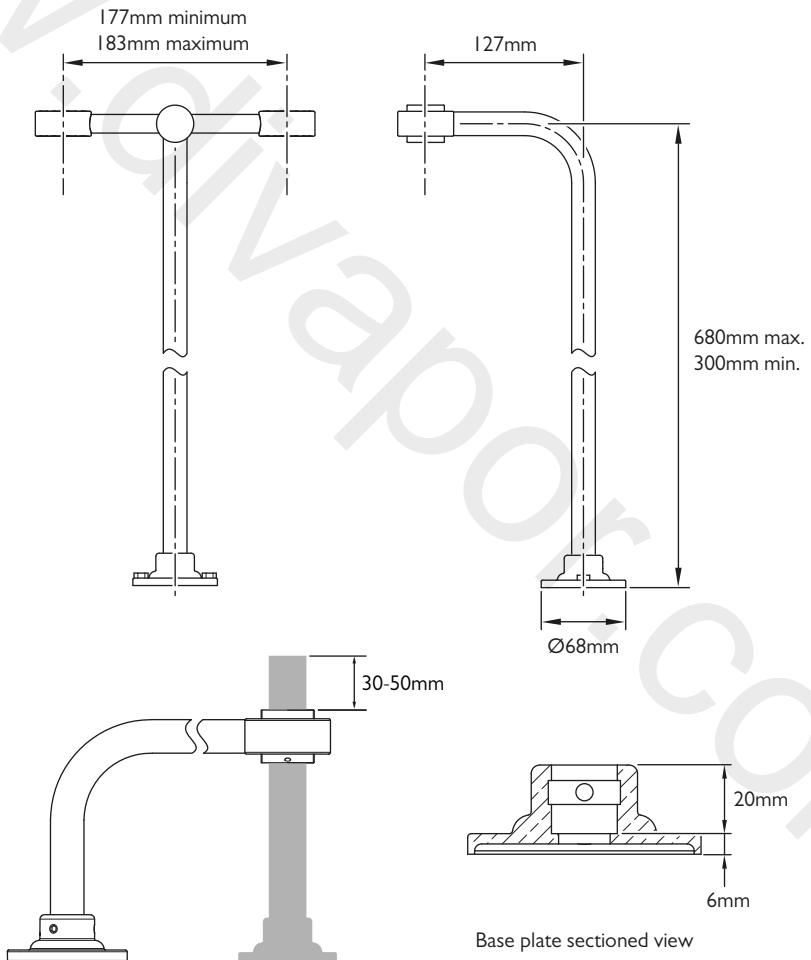

INSTALLING THE SUPPORT

- 1 Cut the bottom of the support arm to the required height.
- 2 Locate the support arm into the base plate. Rotate the base plate to ensure the screw holes are in the correct orientation. Secure using the three set screws and hexagonal key supplied.

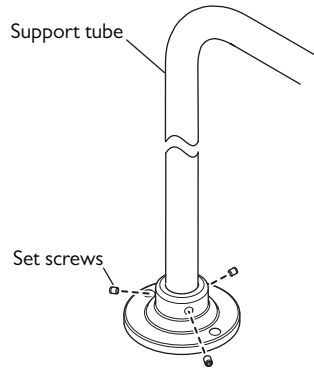

- 3 Carefully pass the standpipe tubes through the support arm and locate them into the floor mounted base plates for the standpipes. Ensure that the standpipe tubes are vertical.
- 4 Mark the screw hole locations.
- 5 Place the standpipe tubes and support to one side then drill suitable sized holes in the floor for the floor fixings.
- 6 Secure the support to the floor using the fixings supplied.

IMPORTANT: Do not secure the standpipe tubes at this stage. Continue to install the standpipes as shown in the guide supplied with them.

To adjust the centres, loosen the set screws on the underside of the support, adjust the side arms to required position and then tighten the set screws to secure.

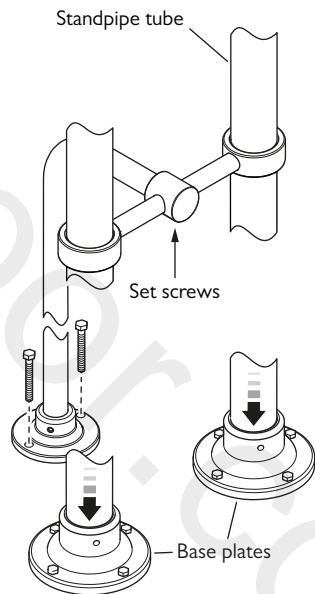



CONTRACT ENQUIRIES

+44 (0)1992 708 316

info@lestroybrooks.co.uk

CUSTOMER SERVICE, SPARES & TECHNICAL ENQUIRIES

+44 (0)1902 390 894

technical@lestroybrooks.co.uk

LEFROYBROOKS.CO.UK

Whilst every effort is made to ensure the accuracy of these, they are subject to change without notice as part of the company's product development process. The use of trademarks, product design and artwork is subject to licence or agreement with LBIP Ltd. The design registrations, trademark registrations and copyrights are protected by law and the use or reproduction outside the terms of an agreement is prohibited. The right to modify designs and dimensions is reserved. LBIP Ltd is a member of ACID (Anti Copying in Design). E&OE