

VII. Exploded Diagram

Twin Valve:

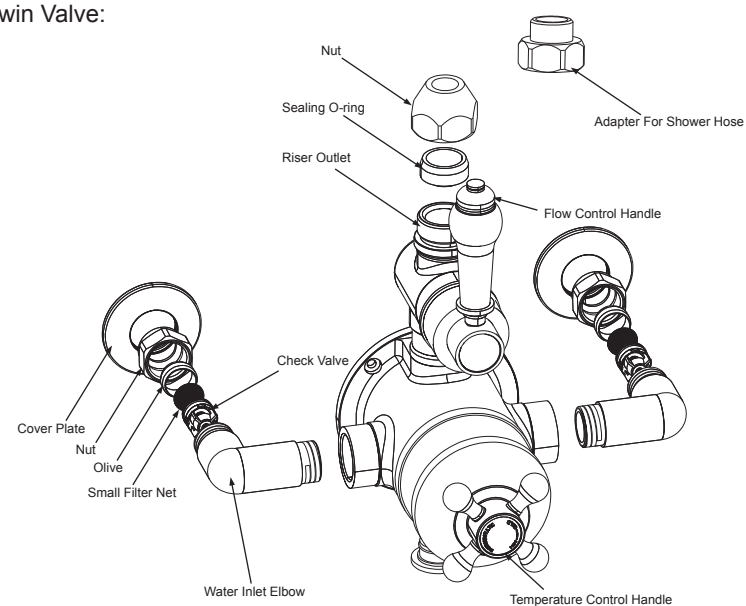

Triple Valve:

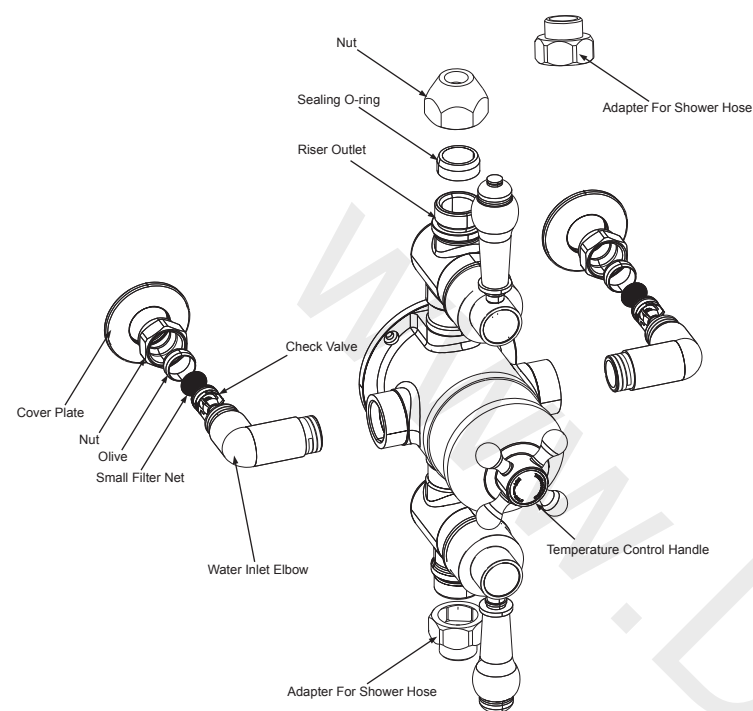

Twin & Triple Exposed Thermostatic Shower Valve

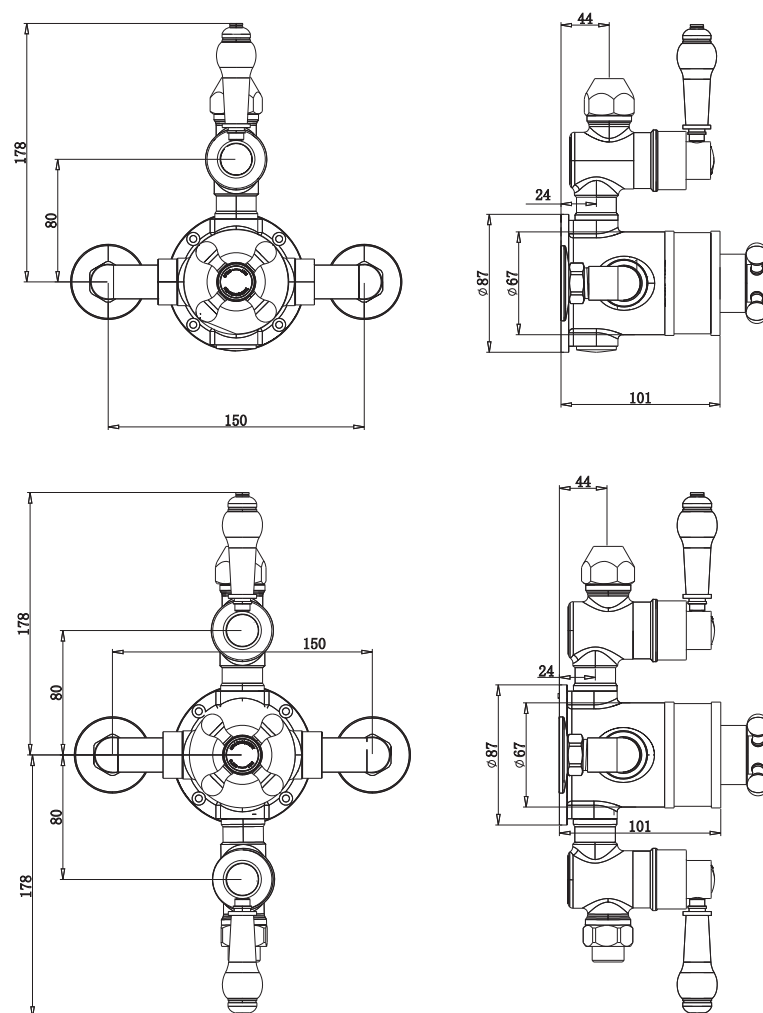

Installation & Maintenance Instructions

Please follow them carefully and leave this manual with end user

I. Operation Notice

- 1.The work condition for use of this product is cold water 4-29°C, hot water 55-85°C and water pressure 0.5-5 bar. And hot & cold water supply pressure should be balanced. The thermostatic cartridge is preferably under the condition of water pressure 3 bar, hot water 65°C and cold water 15°C.
- 2.Make sure the faucet is off when no water comes out of it (especially when nobody resides in the house or during the period of decoration or the absence of water).
- 3.When the room temperature drops below 0°C, take necessary measures (such measure as keeping faucet warm and closing windows) to prevent the faucet from being frozen or even broken (especially when windows kept open for air ventilation while nobody resides in).
- 4.Fitting isolating valves to the inlet feeds is recommended for ease of maintenance.
- 5.Do not disassemble the valve unless you are an expert.

II. Installation

- 1.Determine the fixing position for the valve.
- 2.The plumbing connection on the inlets are 15mm compression fittings. The outlet fittings are either 18mm for rigid riser kits or 1/2" BSP male thread.
- 3.Prepare the supply pipes (hot on the left and cold on the right) at the required height with a width of 150mm centres, making the ends of the pipes 20mm out from the face of the wall, not exceed.
- 4.Hot water inlet to be connected with hot supply on the left of the valve, cold water inlet to connected with cold supply on the right of the valve, which are clearly marked. Make sure that they are correctly connected, otherwise, the thermostatic cartridge will lose its function of controlling temperature and may cause scald.
- 5.Prior to installation and connecting, make sure the pipes are thoroughly flushed to remove any debris etc. Attention: Failure to do this will impair the flow of water.
- 6.Place the valve over pipes, mark the position of the 4 holes that are cast into the base of the body. Drill suitable length holes at the marked positions. Use supplied plugs and screws to secure the shower valve.
- 7.Push the riser into the top riser outlet, tighten the nut. For triple valve, connect the hose nut onto the bottom 1/2" BSP male thread.
- 8.Then turn on the water supply. Check that there is no leakage.
- 9.Check the maximum water temperature from the terminal fitting with a thermometer. The recommended maximum temperature is 42°C.

III. Maintenance

If the water flow is less than normal and temperature control is imprecise after a period of usage. It is often due to the poor water which blocks the small filter net or check valve. The cleaning method: At first, turn off the main valve. Remove the valve by loosening the nuts and grub screws. Remove the water inlet elbows, you can see the check valve and small filter net inside. Clean it with brush and vinegar. After completion, rinse it and reassemble all the parts back. At last, check the water flow and temperature control.

IV. Aftercare

Always clean the surface of shower valve to keep it bright. Attention: please do not use inappropriate tools such as sharp brushes, rough sponges, scouring pads or corrosive detergent to clean the shower valve. Please clean the shower valve by wet cloth and soapy water after each time of usage. Then rinse the soap out with clean water and dry with a soft cotton cloth.

VI. Faulty Diagnosis

FAULT	POSSIBLE CAUSE
Shower only runs hot or cold after installation	1.Hot and cold supplies have been plumbed the wrong way around. 2.Faulty thermostat.
Shower does not run hot enough	1.Check hot water supply temperature. 2.Blockage in the hot supply.
Hot water in cold supply or vice versa	1.Check and clean non-return valves
Low or no flow	1.Possible blockage in the system. 2.Operating conditions are incorrect. 3.Valve shut off as been activated due to a pressure drop in either the cold or hot supplies.
Leaking when in the off position	1.Debris in flow control cartridge. 2.Faulty flow control cartridge.
Fluctuating flow	1.Dynamic inlet pressure are not balanced. 2.Faulty thermostatic cartridge.