

GENERAL FITTING GUIDE

THERMOSTATIC BAR SHOWER MIXER with RIGID RISER KIT

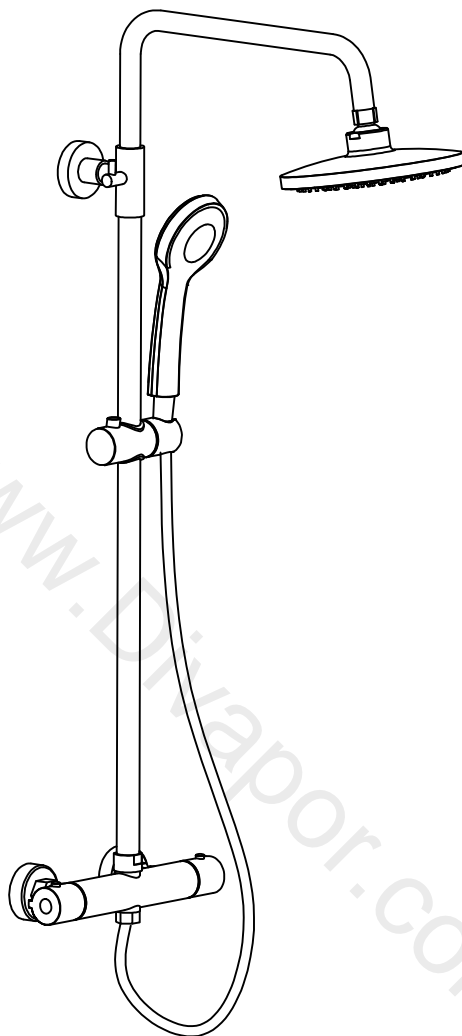

GUARANTEE & AFTERCARE

When installing or using tools, extra care must be taken to avoid damaging the finish or fitting. To maintain the appearance, please ensure it is cleaned regularly using a clean soft damp cloth only. Abrasive cleaners or detergents must not be used as they may cause surface deterioration. The company provides a guarantee against faulty material or manufacture excluding serviceable parts, providing they have been installed, cared for and used in accordance with our instructions.

Any misuse will invalidate your guarantee

WATER SUPPLY REGULATIONS

This product has been manufactured to comply with the appropriate BS EN Standards and to conform to Water Supply Regulations 1999.

EARTH BONDING

Earth any new pipework satisfactorily (Seek expert advice if in doubt).

The company reserves the right to continually evolve its product lines without notification. The company will not accept any liability regarding specification changes and their consequences unless previously quoted by the company in writing.

INSTALLATION

1. Please check that all components are present.
2. Before installation ensure that all feed lines are clear of debris and isolation service valves are fitted for any subsequent servicing that may be required.
3. Ensure water pressure is 1 bar minimum.
4. Pictures in the manual are general in content and may not represent exactly your purchased shower unit. If you are having difficulties please contact a professional plumber.

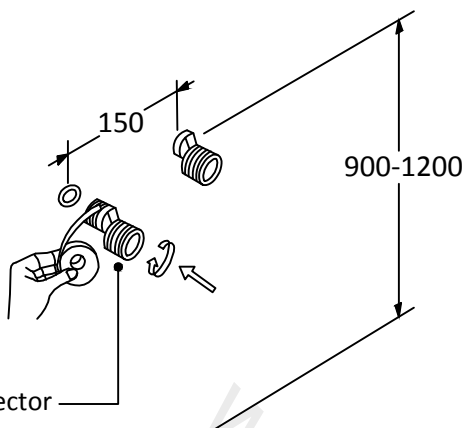
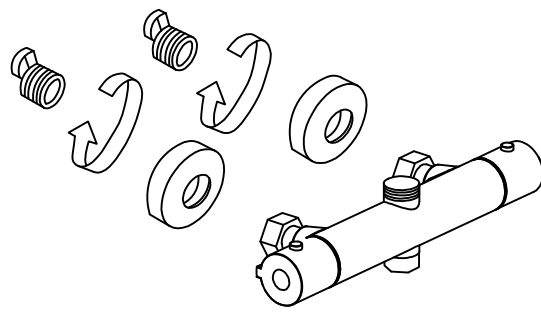
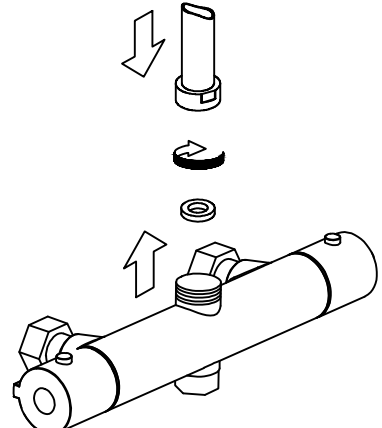
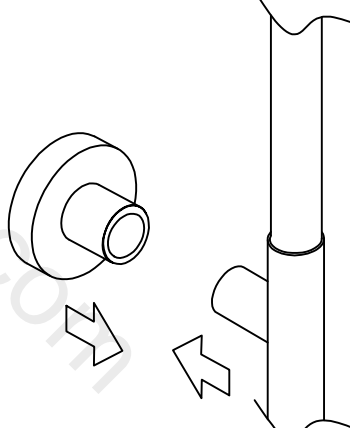
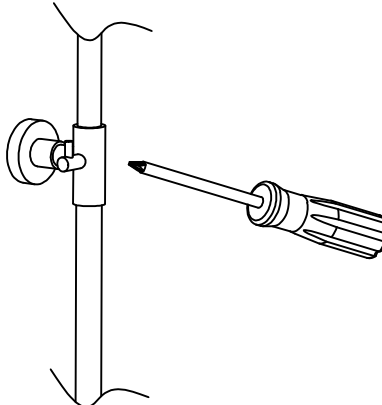
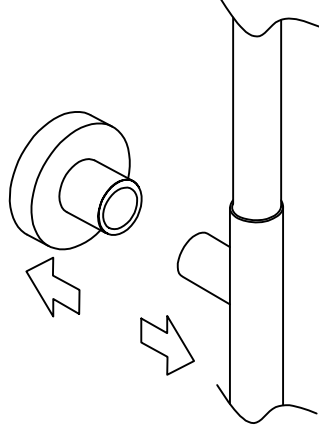
<p>1</p>  <p>Offset Connector</p> <p>Apply PTFE tape to threads of offset connectors; connect offset connectors onto inlet pipes.</p>	<p>2</p>  <p>Fit decorative covers over the offset connectors. Then insert sealing washer into nut and tighten onto offset connectors with wrench, being careful not to damage the chrome finish on the connecting nuts.</p>
<p>3</p>  <p>Install the riser into the top outlet of the shower valve.</p>	<p>4</p>  <p>Fit the wall bracket to the riser kit</p>
<p>5</p>  <p>Make sure the riser is level, mark the position of the screw holes on the wall bracket.</p>	<p>6</p>  <p>Remove the riser.</p>

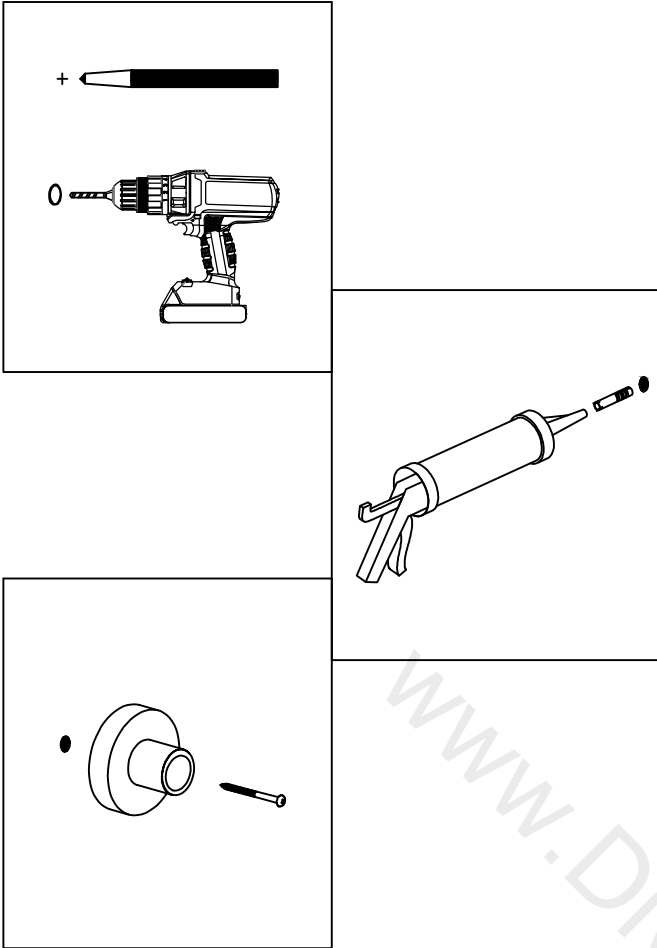
7

Drill the screw holes and install the wall plugs.
To create a seal, apply a small amount of silicone
on the inside of the wall plug.

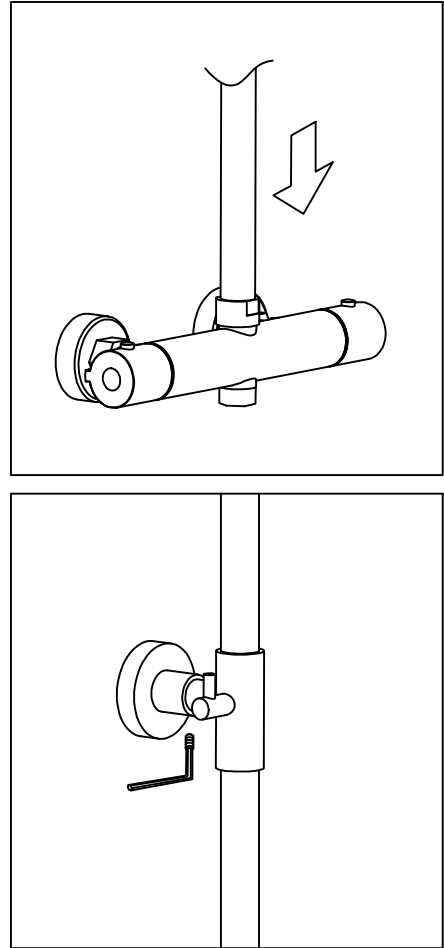
8

Install the riser on the wall bracket, tighten the
screw.

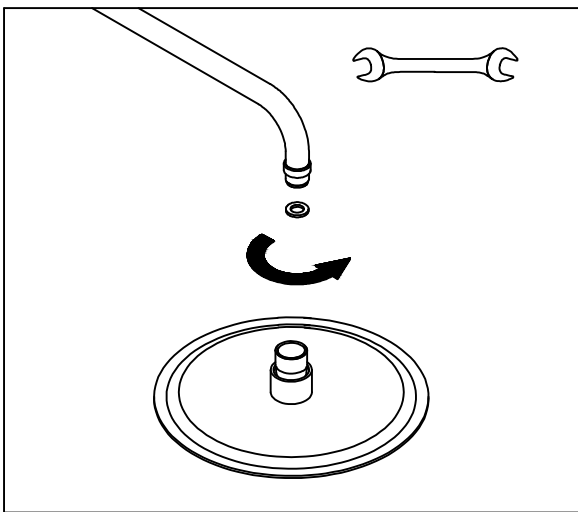
9

Install the shower head.

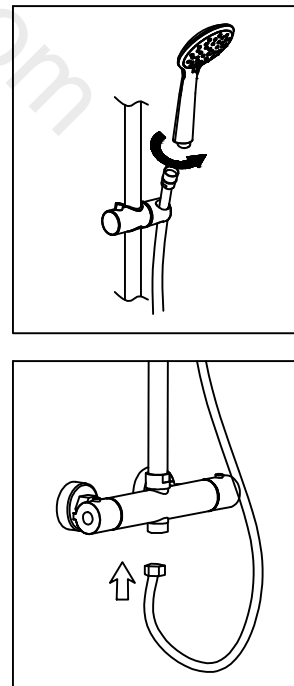
10

Connect the shower hose to the bottom outlet on
the shower valve, and screw the conical end to the
shower handset. Place the conical end of the
shower flex into the parking bracket on the riser rail.

COMMISSIONING & SAFETY TEMPERATURE ADJUSTMENT

The shower valve temperature is factory pre-set to a safe 38 degrees at the temperature handle safety stop point, but under certain site conditions, calibration may be required to achieve this safety set point, if required. Please follow the procedure below to calibrate the shower to the 38 degrees safety stop point.

- Check - The hot water supply temperature **Must be 55 - 65 degrees.**
- Turn the flow control handle to the maximum flow.
- Turn the temperature handle anti-clockwise to the temperature safety stop point and check the temperature of the water from the outlet. If the water temperature is not achieving 38 degrees, please follow the procedure below.
- Remove the temperature handle and put to one side.
- The temperature cartridge stop lug and thermostatic cartridge spline will now be visible.
- Relocate the temperature handle onto the thermostatic cartridge spline by a few mm - enough to just engage with the thermostatic cartridge spline, but not so it comes into contact with the temperature cartridge stop lug.
- To **DECREASE** the water temperature turn the temperature handle clockwise by a few increments and allow the temperature to stabilise - measure the outlet water temperature. Repeat this process as necessary until 38° C is reached.
- To **INCREASE** the water temperature turn the temperature handle anti-clockwise by a few increments and allow the temperature to stabilise - measure the outlet water temperature. Repeat this process as necessary until 38° C degrees is reached.
- Re-fit the temperature handle - being careful not to further adjust the 38° C set point, carefully remove the temperature handle and relocate it back onto the thermostatic cartridge spindle, ensuring that the temperature handle override button pin is set against the thermostatic cartridge stop lug. This will stop the user accidentally setting the showering temperature beyond 38° C unless they use the override button.
- Re-secure the thermostatic handle in place.

FAULT DIAGNOSIS

FAULT	POSSIBLE CAUSE	ACTION REQUIRED
1. The showering water temperature is too hot.	1.1 Temperature set point incorrectly commissioned.	1.1.1 Please see 'Commissioning & Safety Temperature Adjustment'.
2. The showering water temperature is too cold.	2.1 Temperature set point incorrectly commissioned.	2.1.1 Please see 'Commissioning & Safety Temperature Adjustment'.
	2.2 Hot water supply temperature not hot enough.	2.2.1 Check that the hot water temperature at a basin tap is acceptable, which should be around 55-60 degrees. If it isn't, make sure the heating appliance is adjusted to increase the hot supply temperature.
		2.2.2 Make sure the heating appliance has sufficient hot water storage capacity.
3. Water is not mixing correctly, or shower temperature is varying.	3.1 Hot and cold water supplies are plumbed to the wrong side of the valve body.	3.1.1 Re-plumb the shower valve with the hot and cold feed feeding to the correct inlet ports of the valve.
	3.2 Combi-boiler is cycling	3.2.1 Contact your boiler service engineer
4. Low or no water flow from shower.	4.1 Operating conditions are incorrect.	4.1.1 See Technical data for correct operating pressures.
	4.2 Water supplies have been cut off.	4.2.1 Check other water outlets elsewhere in the house, and contact water authority if necessary.
	4.3 Shower unit or outlet may be blocked (handset, shower head etc).	4.3.1 Check if shower outlet is blocked. Clean as necessary.
	4.4 Valve anti-scald has activated due to operating conditions.	4.4.1 See Technical data for correct operating pressures and inlet water supply temperatures.
	4.5 Possible blockage in the system.	4.5.1 Check & clean any filters as necessary.
4.5.2 Supply pipe work may be blocked. Consult a qualified installer.		
4.5.3 Make sure any in line service isolator valves are in the fully open position.		
5. Leak when shower valve in the "off" position.	5.1 Check that the leak is from the shower valve and not residual of water in the shower head/handset.	5.1.1 Remove the shower head/handset from it's feed to see if any water is dripping from the flexible hose or shower arm. If this is not leaking you are experiencing residual water in the shower fitting which is not a fault.
		5.1.2 If the leak is from the shower valve, a new flow control cartridge is required.